

EML Model

Features

- Be used to drive the feed shaft of various machinery
- Various models (1.0kW~4.0kW, with brake, etc.)
- Mounted with 17/20bits incremental / absolute encoder, wire-saving incremental encoder (2500P/R) is optional
- Standard configuration is IP65

Application

- Machine tools
- Handling machinery
- Food processing machinery
- Textile machinery



Specification Description

EML-10

EML Model Servo Motor

A

Rated Output Power

D

Power Voltage

A

Encoder

Designing Sequence

1

Shaft End

1

Option Parts

Sign	Spec.	Sign	Spec.	Sign	Spec.	Sign	Spec.	Sign	Spec.	Sign	Spec.
10	1.0kW	A	200VAC	D	Incremental Encoder: 131072P/R	A,B	Designing Sequence	1	Flat, Without Keys	1	None
20	2.0kW	D	400VAC	F	Incremental : Encoder 1048576P/R			2	Flat, With Keys With Screw Thread	2	With Oil Seal
30	3.0kW			S	Absolute Encoder: 131072P/R					3	With Brake (DC24V)
40	4.0kW			P	Incremental Wire-saving Type: 2500P/R					4	With Oil Seal, With Brake (DC24V)

Notes: ① The EML-20□□A□□, EML-30□□A□□, EML-40□□A□□ servo motors are not mounted the incremental encoder 131072P/R.
 ② There is no brake in the EML-10□□□□□ servo motor.

Rated Value and Specification

Voltage		200VAC / 400VAC									
Servo Motor Model	EML-	10A□A□□	10A□B□□	10D□A□□	10D□B□□	20A□A□□	20D□A□□	30A□A□□	30D□A□□	40A□A□□	40D□A□□
Rated Output Power	kW	1.0	1.0	1.0	1.0	2.0		3.0		4.0	
Rated Torque	N.m	9.55	9.55	9.55	9.55	19.1		28.7		38.2	
Instantaneous Peak Torque	N.m	28.7	28.7	28.7	28.7	57.3		86.0		114.6	
Rated Current	Arms	6.0	5.5	3.2	2.8	12.0	6.2	18.0	9.0	24.0	12.2
Instantaneous Max. Current	Arms	18.0	16.5	9.6	8.4	36.0	18.6	54.0	27.0	72.0	36.6
Rated Speed	r/min	1000									
Max. Speed	r/min	1500									
Rotor Moment of Inertia	$\times 10^{-4} \text{kg}\cdot\text{m}^2$	19.0 (19.6)	23.5(24.6)	19.0 (19.6)	23.5(24.6)	53.5 (56.7)		77.8 (81.0)		102.2 (105.4)	
Brake Rated Voltage		DC24V \pm 10%									
Brake Rated Power	W	19	19.5	19	19.5			35			
Brake Holding Torque	N.m	10	12	10	12			40			
Encoder	Standard	Incremental Encoder: 131072P/R 1048576P/R				Absolute Encoder: 131072P/R					
	Options	Absolute Encoder: 131072P/R Wire-saving Incremental Encoder (2500P/R)									
Insulation Class		F									
Ambient Temperature		0 to + 40°C (No freezing)									
Ambient Humidity		20 to 80% RH (Non-condensing)									
Vibration		24.5m/s ²									
Enclosure		Totally Enclosed, Self-cooled, IP65 (Except for shaft opening, when not equipped with oil seal.)									

Note: The values in parentheses are for servo motors with holding brakes.

Torque-Speed Feature

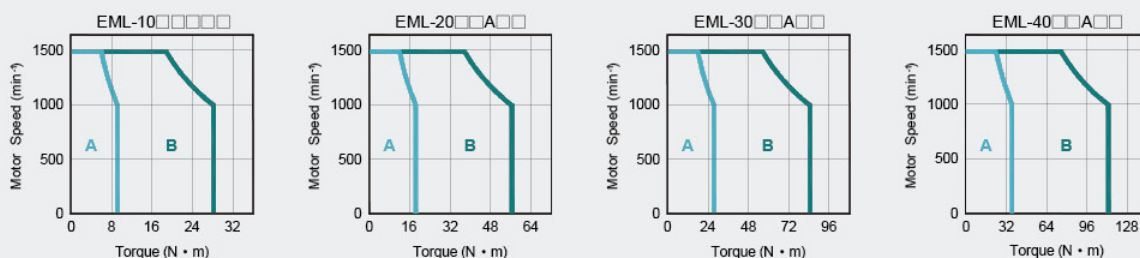

A: Continuous Working Area B: Repeatedly Working Area

EMG-□□□□A & EML-□□□□A Dimension

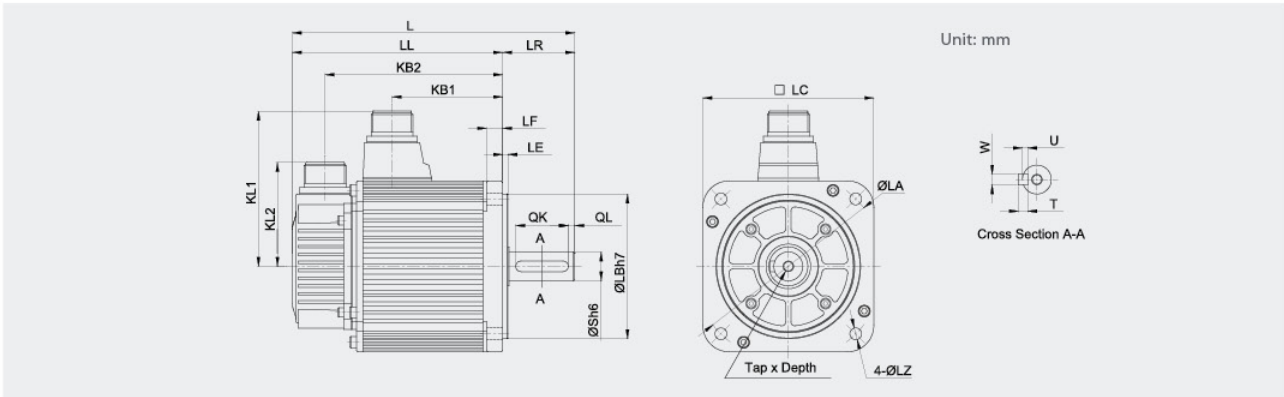

Model EMG-	L	LL	KB1	KB2	KL1	KL2	Dimension							S	Tap xDepth	Key				
							LR	LE	LF	LC	LA	LB	LZ			QK	QL	W	T	U
10□P/S/A	215(269.5)	160(214.5)	84	135(189.5)	118	79	55	4	12	130	145	110	9	22	M6x20L	40	5	8	7	4
10□DA	215	160	84	135(192)	118	79	55	4	12	130	145	110	9	22	M6x20L	40	5	8	7	4
15□P/S/A	240(294.5)	185(239.5)	109	160(214.5)	118	79	55	4	12	130	145	110	9	22	M6x20L	40	5	8	7	4
15□DA	240	185	109	160(217)	118	79	55	4	12	130	145	110	9	22	M6x20L	40	5	8	7	4
20□P/S/A	265(319.5)	210(264.5)	134	185(239.5)	118	79	55	4	12	130	145	110	9	22	M6x20L	40	5	8	7	4
20□DA	265	210	134	185(242)	118	79	55	4	12	130	145	110	9	22	M6x20L	40	5	8	7	4
30□□	307(378)	228(299)	143	203(274)	140	79	79	3.2	18	180	200	114.3	13.5	35	M8x16L	55	6	10	8	5
50□□	357(428)	278(349)	183	253(324)	140	79	79	3.2	18	180	200	114.3	13.5	35	M8x16L	55	6	10	8	5

Model EML-	L	LL	KB1	KB2	KL1	KL2	Flange side							S	Tapx Depth	Key				
							LR	LE	LF	LC	LA	LB	LZ			QK	QL	W	T	U
10□□A	265(319.5)	210(264.5)	134	185(187.5)	118	79	55	4	12	130	145	110	9	22	M6x20L	40	5	8	7	4
20□□A	332(401)	253(322)	168	228(245)	140	79	79	3.2	18	180	200	114.3	13.5	35	M8x16L	55	6	10	8	5
30□□A	372(443)	293(364)	208	268(287)	140	79	79	3.2	18	180	200	114.3	13.5	35	M8x16L	55	6	10	8	5
40□□A	412(478)	333(399)	243	308(322)	140	79	79	3.2	18	180	200	114.3	13.5	35	M8x16L	55	6	10	8	5

Note: The dimension in parentheses are for servo motors with holding brakes.

Motor Connector Specification

- Receptacle:
 - MS3102A20-4P (LC=130)
 - MS3102A22-22P (LC=180)
- Plug:
 - MS3108B20-4S (LC=130)
 - MS3108B22-22S (LC=180)
- Cable Clamp:
 - MS3057-12A



Pin No.	Signal
A	U
B	V
C	W
D	FG

Brake Connector Specification

- Receptacle:
 - MS3102A10SL-3P
- Plug:
 - MS3106A10SL-3S
- Cable Clamp:
 - MS3057-4A



Pin No.	Signal
A	B1
B	B2
C	-

Encoder Connector Specification

- Receptacle: MS3102A20-29P
- Plug: MS3108B20-29S
- Cable Clamp: MS3057-12A



Wire-saving Incremental Encoder

Pin No.	Signal
A	A+
B	A-
C	B+
D	B-
E	C+
F	C-
G	PG0V
H	FG5V
J	FG

Incremental / Absolute Encoder

Pin No.	Signal
K	S+
L	S-
★T	BAT+
★S	BAT-
H	PG5V
G	PG0V
J	FG

★ Note : There are no BAT+,BAT- signal in incremental encoder.

EMG-□□□□B & EML-□□□□B Dimension

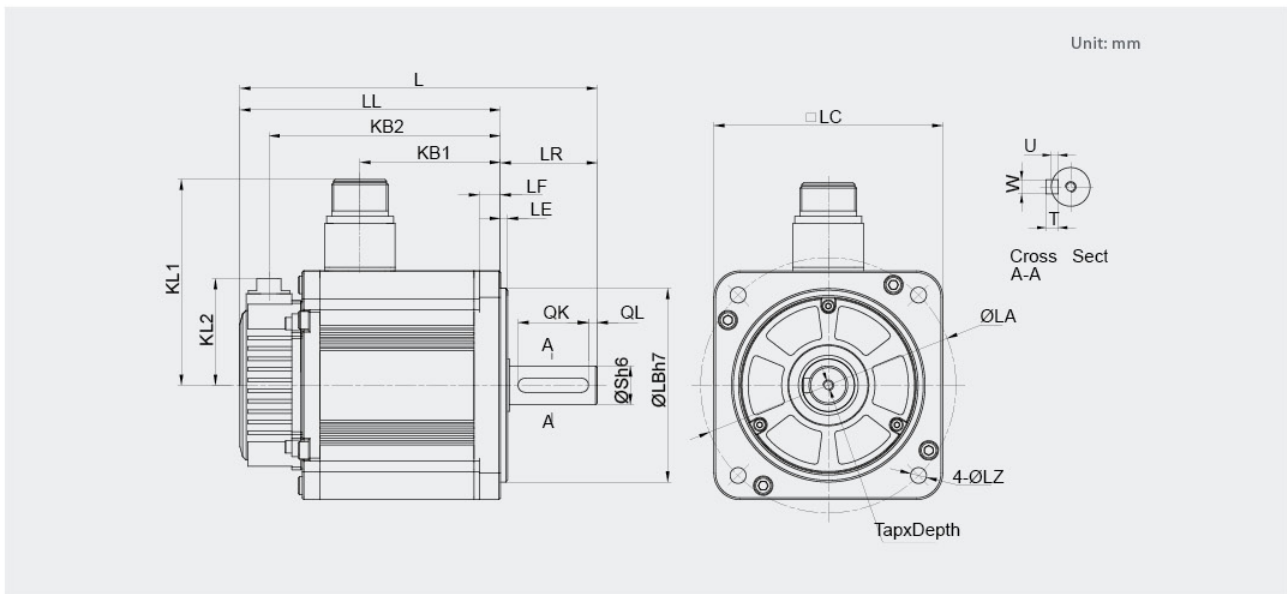

Model EMG-	L	LL	KB1	KB2	KL1	KL2	Dimension							S	TapxDepth	Key				
							LR	LE	LF	LC	LA	LB	LZ			QK	QL	W	T	U
10□□B	203(245.5)	148(190.5)	80(103.2)	131.5(174)	117	60.5	55	4	12	130	145	110	9	22	M6×20L	40	5	8	7	4
15□□B	225(267.5)	170(212.5)	102(125.2)	153.5(196)	117	60.5	55	4	12	130	145	110	9	22	M6×20L	40	5	8	7	4
20□□B	247(289.5)	192(234.5)	124(147.2)	175.5(218)	117	60.5	55	4	12	130	145	110	9	22	M6×20L	40	5	8	7	4

Model EML-	L	LL	KB1	KB2	KL1	KL2	Flange side							S	TapxDepth	Key				
							LR	LE	LF	LC	LA	LB	LZ			QK	QL	W	T	U
10□□B	247(289.5)	192(234.5)	124(147.2)	175.5(218)	117	60.5	55	4	12	130	145	110	9	22	M6×20L	40	5	8	7	4

Note: The dimension in parentheses are for servo motors with holding brakes.

Motor Connector Specification

- Receptacle: HMS3102E20-18P
- Plug: HMS3106AE20-18S

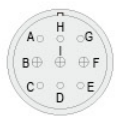

Pin No.	Signal
A	-
B	U
C	FG
D	FG
E	-
F	W
★G	B1
★H	B2
I	V

★ Note : There are no B1,B2 signals in motor without brake.

Encoder Connector Specification

- Receptacle: M-CAN-CM1002-10P
- Plug: M-CAN-CM1008-10S



Wire-saving Incremental Encoder

Pin No.	Signal
1	A+
2	A-
3	B+
4	B-
5	C+
6	C-
7	PG0V
8	PG5V
10	FG

Incremental / Absolute Encoder

Pin No.	Signal
1	S+
2	S-
3	BAT+
4	BAT-
7	PG0V
8	PG5V
10	FG